

# N300 DIGITAL PANEL METER

## FEATURES:

- three-colour display
- LPConfig Program
- MOD BUS
- RTC
- 21 points charact.
- Password protection
- IP65

## INPUTS:

- Hz
- Waveform icons

## OUTPUTS:

- 0/4..20 mA
- 0..10 V
- Waveform icons
- 2x
- 2x
- RS 485

## GALVANIC ISOLATION:

- Supply
- RS 485

Export department:  
+48 68 45 75 139 / 305/  
321 / 386  
Fax: +48 68 32 54 091  
e-mail: export@lumel.com.pl

LUMEL S.A.  
ul. Słubicka 1  
65-127 Zielona Góra  
POLAND  
[WWW.LUMEL.COM.PL](http://WWW.LUMEL.COM.PL)



- Measurement: number of pulses, frequency, rotational speed, period, worktime counter.
- Two impulse counters, co-operation with encoders.
- Counter of actual and total values.
- 3-colour display (14 mm high), programmable in 3 ranges of the measured value.
- Meter programming from keyboard or through the RS-485 interface by means of the free LPConfig program.
- 4 alarm outputs with signalling on LED diodes, working in 6 different modes.
- Conversion of any measured value into an analog signal 0/4...20 mA or 0...10 V.
- Storage of minimal and maximal values for all measured quantities.
- Supply of object transducers (option).
- 21-point individual characteristic for the measured value.
- Mathematical function.
- Firmware updating (option).

## EXAMPLE OF APPLICATION

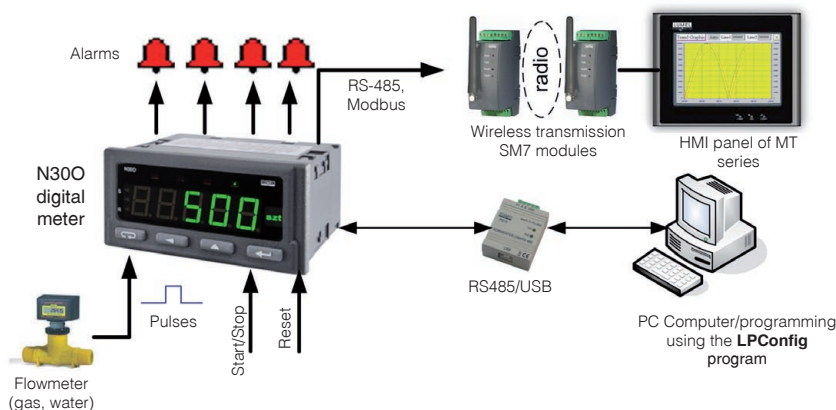

Measurement and visualization of the water/gas flow. The measured value is transmitted to the operating panel via radio modules

## INPUTS

Input signal:	Input kind	Indication range	Maximal frequency of input signal	Class	Remarks
Voltage 5...36 V d.c.	Number of pulses IN1/IN2	-19 999..99 999	10 kHz/ 8 kHz	±1 pulse	with signal filtering 2 kHz
	Frequency < 10 kHz	0.05..99 999 Hz	100 kHz	0.01	with signal filtering 100 Hz
	Frequency > 10 kHz	1...99 999 Hz (measuring range up to 1 MHz)	1 MHz	0.01	
	Rotational speed	0.05...99 999 [rpm]	100 kHz	0.01	
	Period t < 10 s	0.0001...11 [s]		0.01	
	Period t < 10 s	0.0001...3600 [s]		0.01	
	Worktime counter	0...99 999 [h]			0.5 sec/ 24 hours
Encoder	-19 999...99 999	10 kHz		with signal filtering 2 kHz	
Current time	00.00...23.59			0.5 sec/ 24 hours	

## OUTPUTS

Output kind	Properties	Remarks
Relay output	<ul style="list-style-type: none"> <li>• 2 x relays, voltageless NOC contacts load-carrying capacity 250 V a.c./ 0.5 A a.c.</li> <li>• 2 x relays, voltageless switched contacts load-carrying capacity 250 V a.c./ 0.5 A a.c.</li> </ul>	
Analog output	<ul style="list-style-type: none"> <li>• current programmable 0/4..20mA, load resistance ≤ 500 Ω</li> <li>• voltage programmable 0...10 V load resistance ≥ 500 Ω</li> </ul>	Error of analog output: <b>0.2% of the set range</b> Additional error from temperature changes: <b>50% of the class/10K</b>
OC output	• typu OC, passive npn, 30 V d.c./30 mA	
Auxiliary supply	• 24 V d.c./ 30mA	

## DIGITAL INTERFACE

Interface type	Transmission protocol	Modes	Baud rates
RS-485	MODBUS RTU	8N2, 8E1, 8O1, 8N1	4.8, 9.6, 19.2, 38.4, 57.6, 115.2 kbit/s

### EXTERNAL FEATURES

Readout field	5-digit LED display - indication range -19999..99999 digit height: 14 mm	three-colour display (color changes depending on displayed value): red, green, orange
Weight	< 0.2 kg	
Overall dimensions	96 × 48 × 93 mm	Panel cut-out: 92 <sup>+0.6</sup> × 45 <sup>+0.6</sup> mm
Protection grade (acc. to EN 60529)	from frontal side: IP65	from rear side: IP 10

### RATED OPERATING CONDITIONS

Supply voltage	85...253 V a.c. (40...400 Hz) or d.c., 20...40 V a.c. (40...400 Hz) or d.c.	power input < 6 VA
Temperature	ambient: -25...+55°C	storage: -33...70°C
Relative humidity	25...95%	condensation inadmissible
Operating position	any	
External magnetic field	0...400 A/m	

### SAFETY AND COMPATIBILITY REQUIREMENTS

Electromagnetic compatibility	Noise immunity	acc. to EN 61000-6-2
	Noise emissions	acc. to EN 61000-6-4
Isolation between circuits	basic	acc. to EN 61010-1
Pollution grade	2	
Installation category	III	
Maximal phase-to-earth operating voltage	for the supply circuit: 300 V for remaining circuits: 50 V	
Altitude above sea level	< 2000 m	

### CONNECTION DIAGRAMS

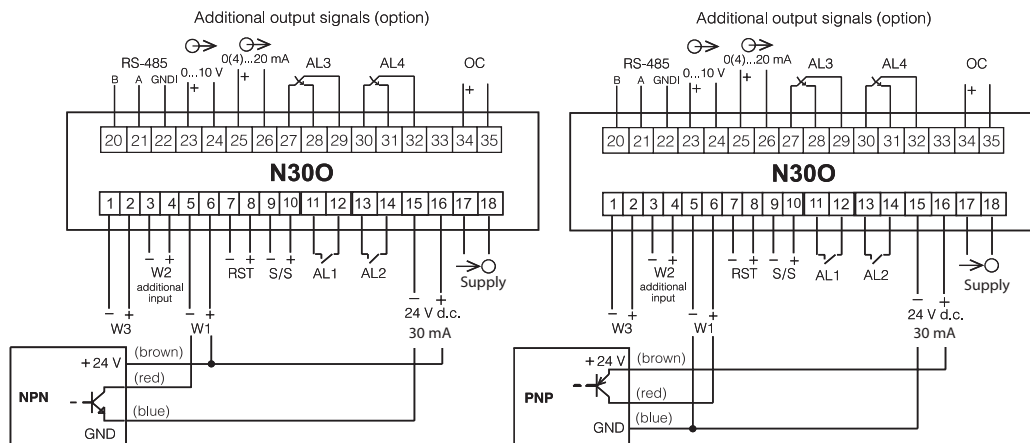

Connections of the transducer with the OC output of NPN and PNP type.

### ORDERING

TABLE 1. ORDERING CODES:

	N300	-	X	X	XX	XX	X	X
<b>Supply:</b>								
85...253 V a.c. (40...400 Hz) or d.c.						1		
20...40 V a.c. (40...400 Hz) or d.c.d.c.						2		
<b>Additional outputs:</b>								
lack							0	
OC output, RS-485, analog outputs								1
OC output, RS-485, analog outputs switched-over relay outputs								2
<b>Unit:</b>								
unit code acc. to the table 2								XX
<b>Version:</b>								
standard								00
custom-made*								XX
<b>Language:</b>								
Polish								P
English								E
other*								X
<b>Acceptance tests:</b>								
without extra requirements								0
with an extra quality inspection certificate								1

**Order example:** The code **N300 - 1 0 01 00 E 0** means:  
**N300** - programmable N300 digital panel meter  
**1** - supply: 85...253 V a.c./d.c.  
**0** - lack of additional outputs  
**01** - unit "V" acc. to tabel 2  
**00** - standard option  
**E** - English language  
**0** - without extra requirements

TABLE 2. CODES OF HIGHLIGHTED UNIT:

Code	Unit	Code	Unit	Code	Unit
00	lack of unit	20	kVAh	40	szt.
01	V	21	MVAh	41	imp
02	A	22	Hz	42	rps
03	mV	23	kHz	43	m/s
04	kV	24	Ω	44	l/s
05	mA	25	kΩ	45	obr/min
06	kA	26	°C	46	rpm
07	W	27	°F	47	mm/min
08	kW	28	K	48	m/min
09	MW	29	%	49	l/min
10	var	30	%RH	50	m <sup>3</sup> /min
11	kvar	31	pH	51	szl./h
12	Mvar	32	kg	52	m/h
13	VA	33	bar	53	km/h
14	kVA	34	m	54	m <sup>3</sup> /h
15	MVA	35	l	55	kg/h
16	kWh	36	s	56	l/h
17	MWh	37	h		
18	kvarh	38	m <sup>3</sup>	XX	on order*
19	Mvarh	39	obr		

\* - after agreeing with the manufacturer

### SEE ALSO:



Free LPConfig software for easy programming of LUMEL's products. Available on our website



KD7 recorder with MODBUS master protocol for recording data measured by N300 meter.



SM3 binary inputs module. For readout of binary states and pulses through RS-485 protocol.

### OUR OFFER



[www.lumel.com.pl](http://www.lumel.com.pl)

For more information about LUMEL's products please visit our website: [www.lumel.com.pl](http://www.lumel.com.pl)

**Export department:**  
 +48 68 45 75 139 /305/  
 321 / 386

**Fax:** +48 68 32 54 091  
**e-mail:** [export@lumel.com.pl](mailto:export@lumel.com.pl)

LUMEL S.A.  
 ul. Słubicka 1  
 65-127 Zielona Góra  
 POLAND  
[WWW.LUMEL.COM.PL](http://WWW.LUMEL.COM.PL)